

# “MÜLLER OPLADEN” Pipe Flame Cutting-Machine

with freely programmable computer control

RB-Elektron 650/1200 AGD

RB-Elektron 950/1500 AGD

RB-Elektron 950/2000 AGD

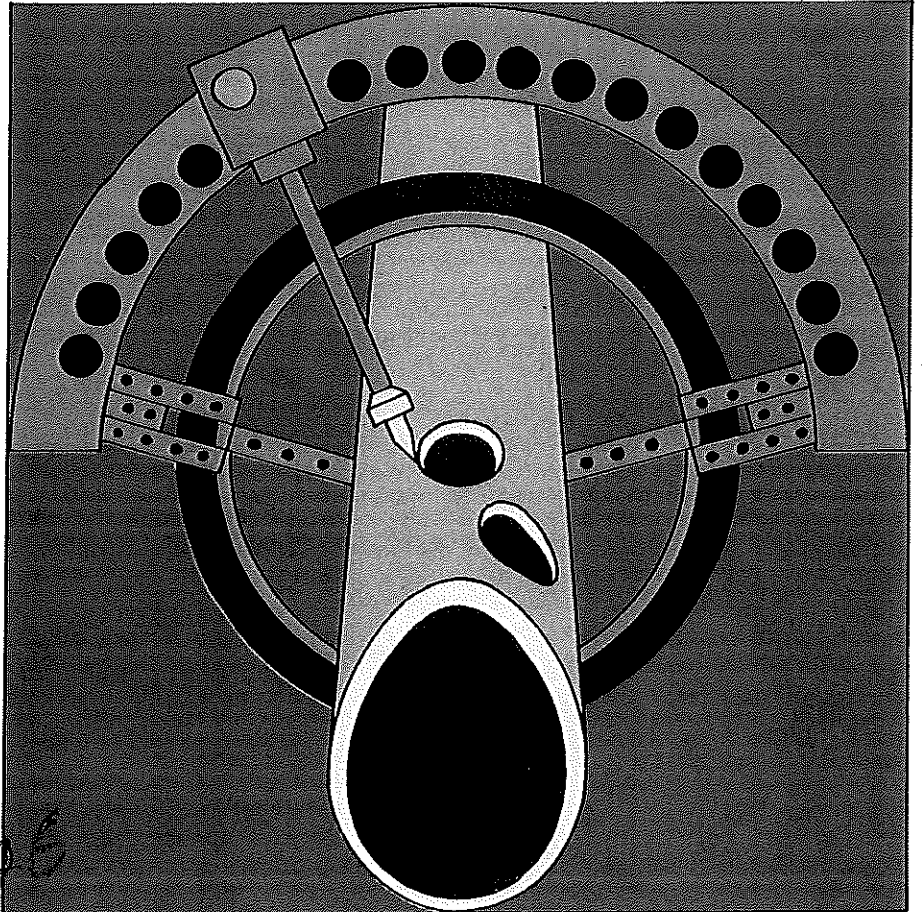

*MR JOSEF, MÜLLER*

*00 49 2111 766208*



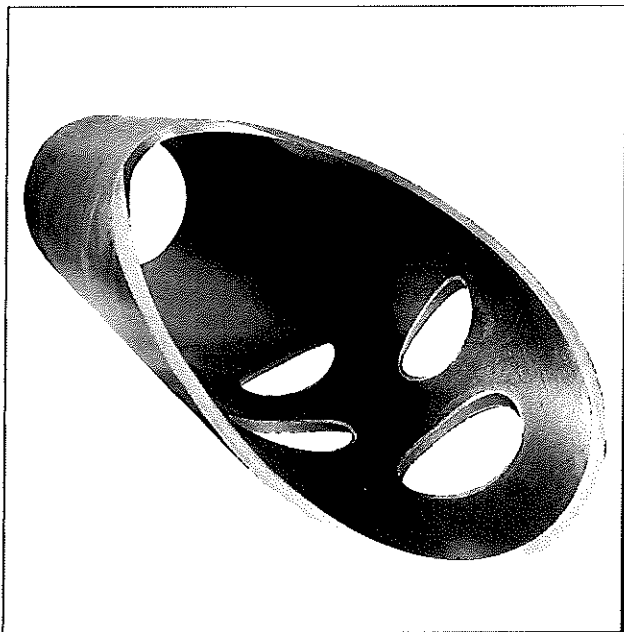
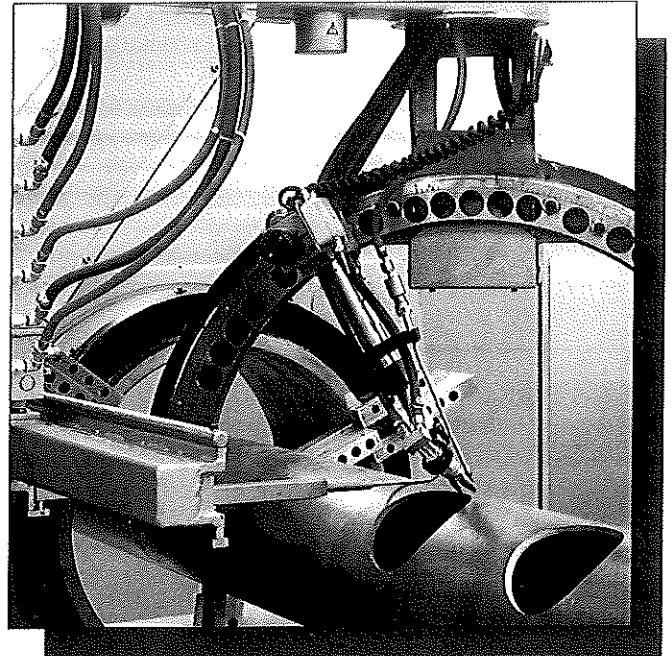
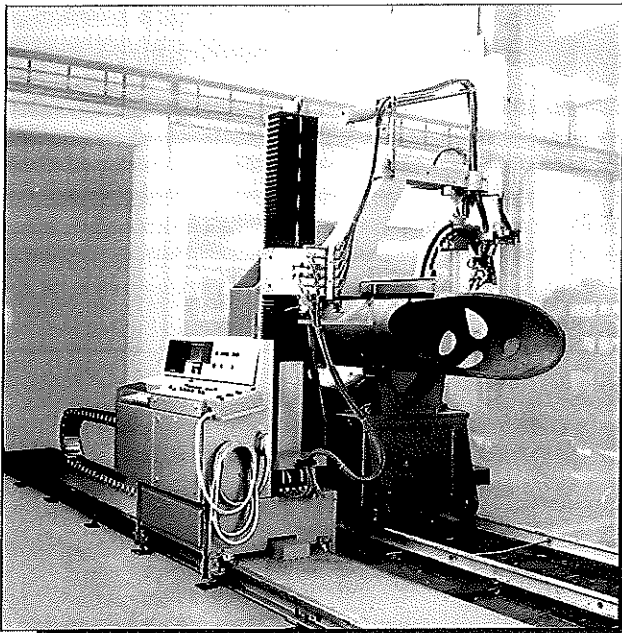

Rohrbrennschneid-  
maschine mit frei  
programmierbarer  
Computersteuerung

Computer Controlled  
Pipe Cutting  
Machine

KLÖCKNER  
WILHELMSBURGER

KLÖCKNER-WILHELMSBURGER GMBH · Borsigstraße 24 · Postfach 1220 · D-2054 Geesthacht

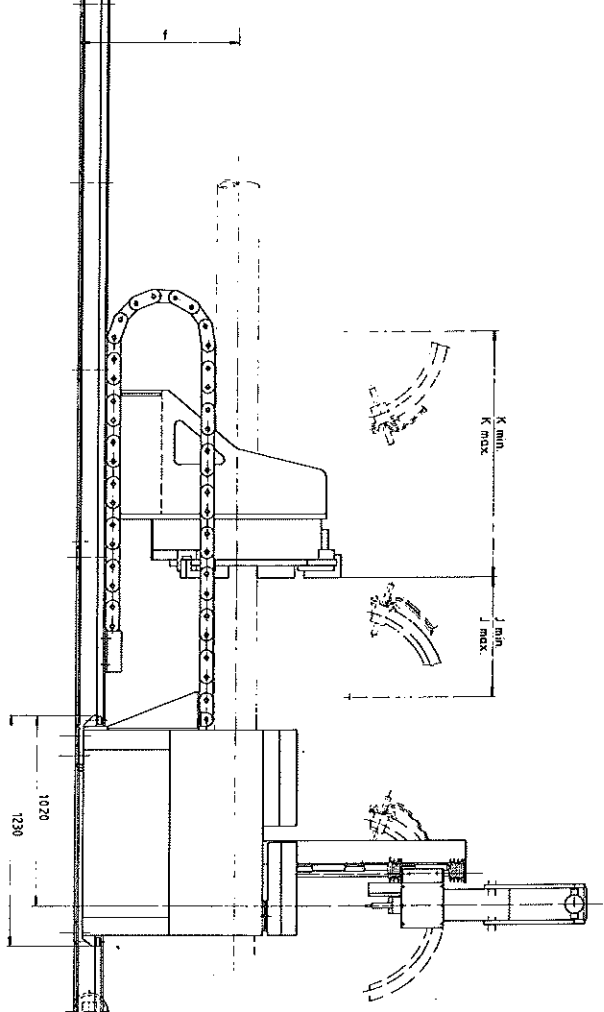
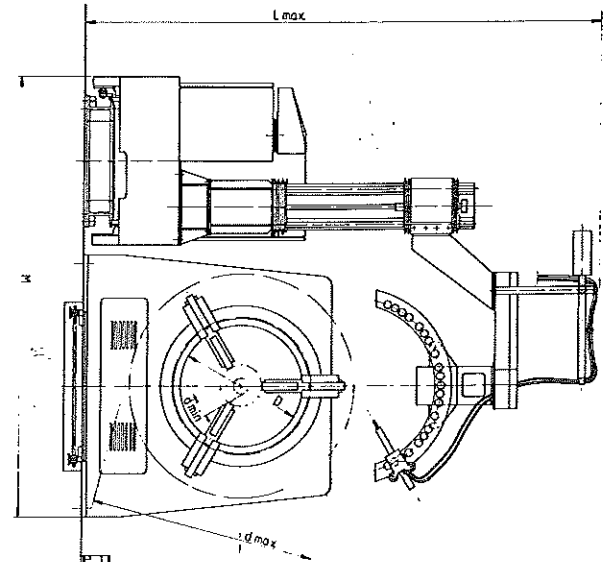

	RB 650/1200	RB 950/1500	RB 950/2000
a	8000	12000	12000
b	7830	11400	11400
c	3500	7000	7000
h	1200	1500	1700
Spur e	750	900	900
f	850	1000	1400
g	830	900	900
D	650	950	950
d min.	80	200	200
d max.	1200	1500	2000
J min.	700	700	700
J max.	4200	8200	8200
K min.	1350	1420	1420
K max.	2500	2500	2500
L	2800	3150	3800
M	2850	2750	2950

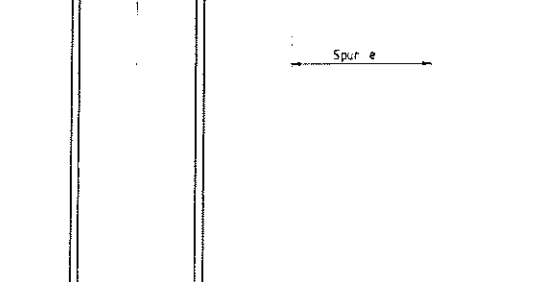
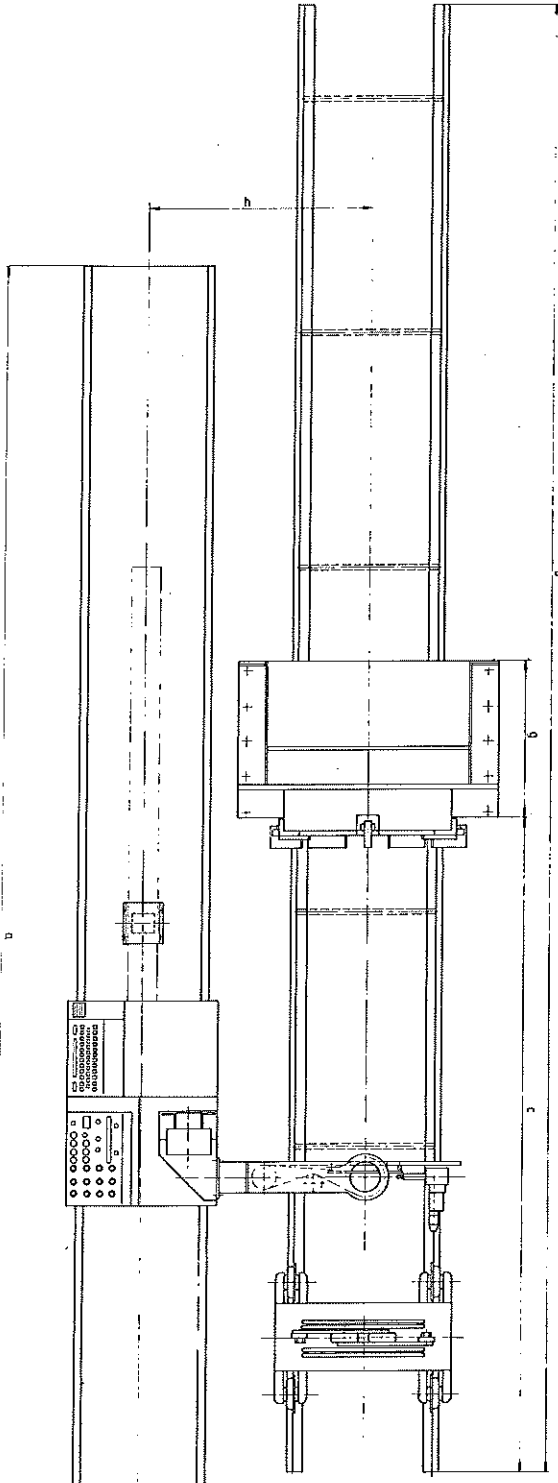

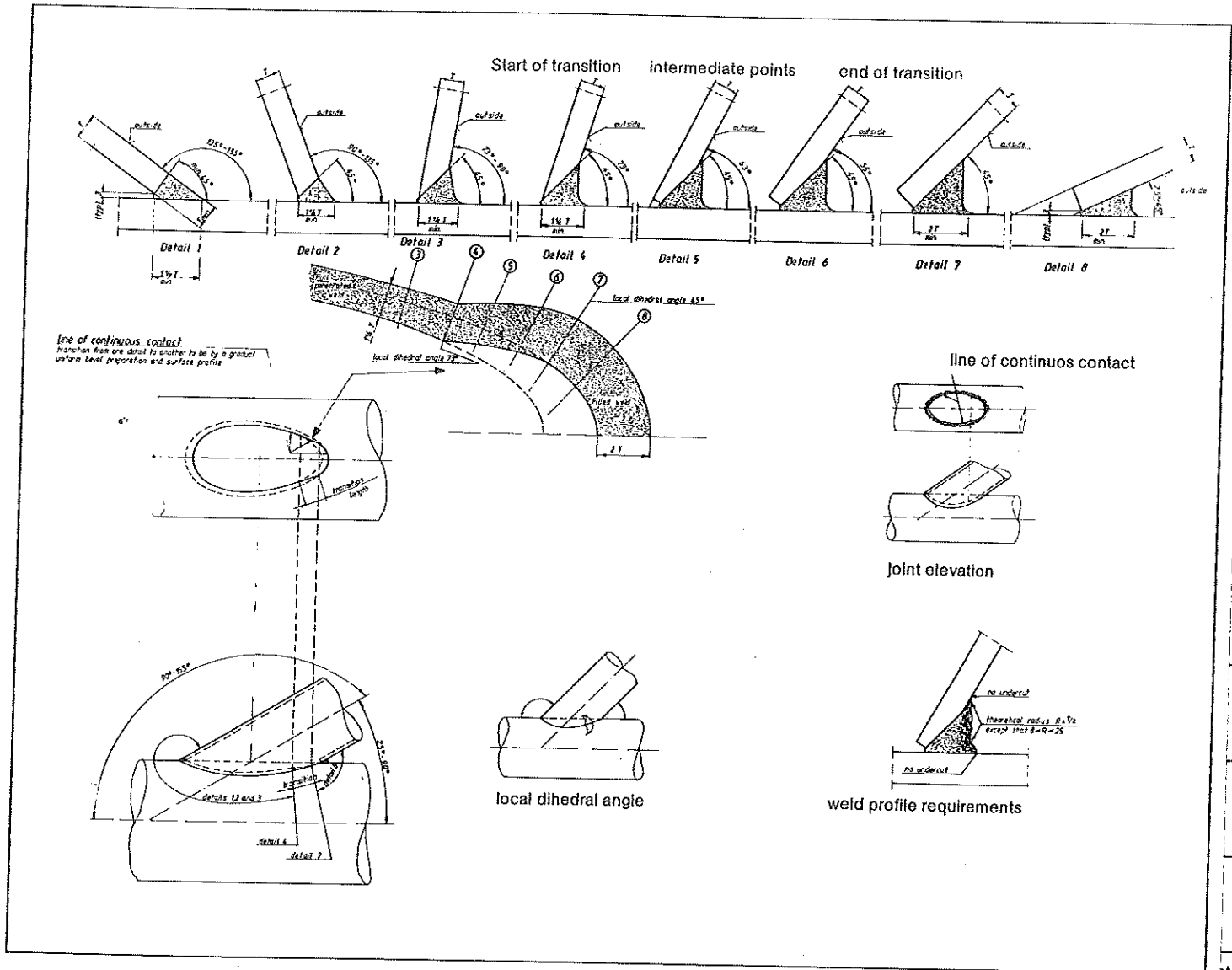

Rohrknoten einer Offshore-Plattform  
 Pipe node of an offshore-platform  
 Nœud de tuyau d'une plateforme offshore  
 Unió de tubos de una plataforma offshore

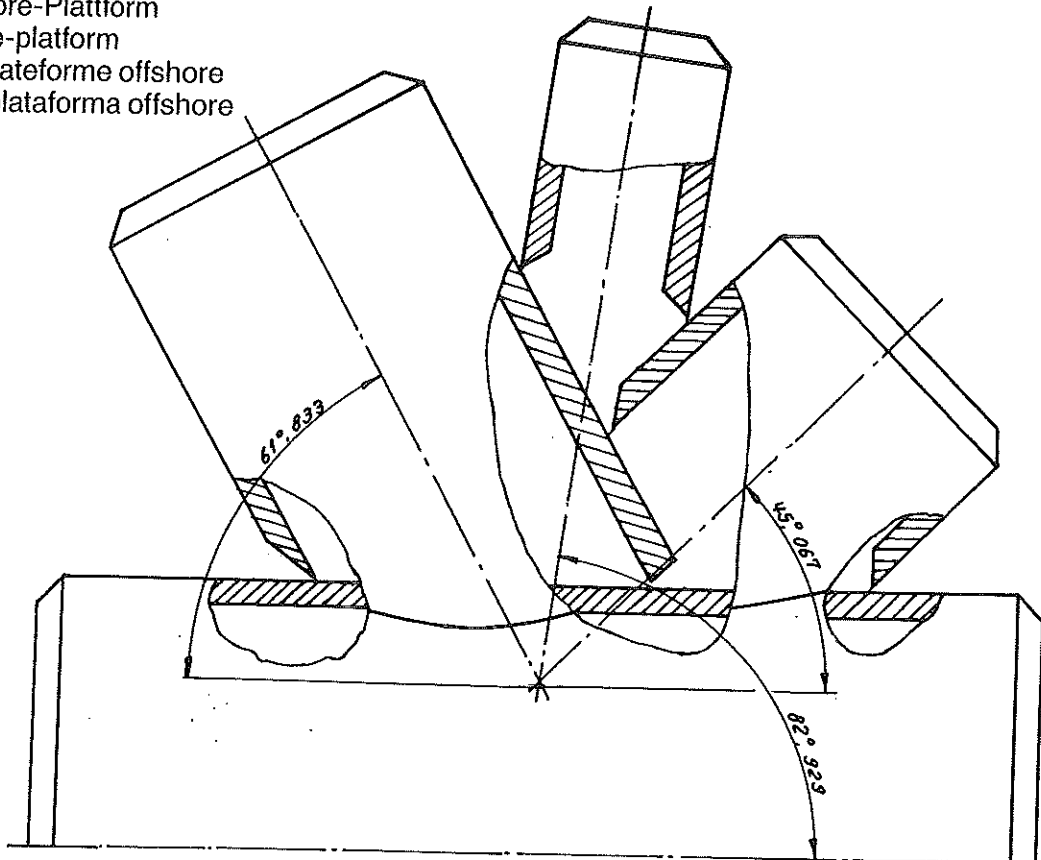

jal  
gr  
tin









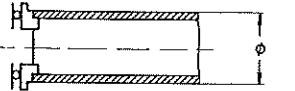
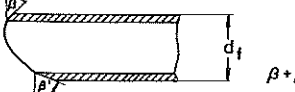
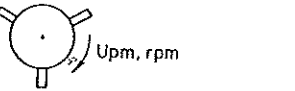

anc  
del

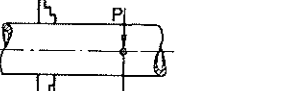
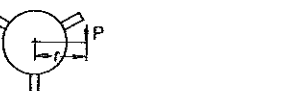
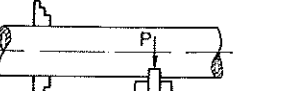
pteur  
la re  
par fi  
la rec  
temp  
temp

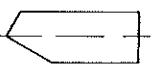
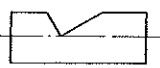
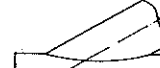
loppe  
le mi  
plet de  
lete d

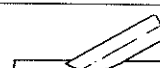
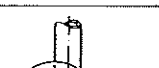
à la m  
ma«

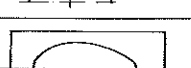
rance:  
of pipe  
ce of a

Données techniques et possibilités de coupe des machines d'oxy-coupage de tubes	Datos técnicos y posibilidades de corte de las máquinas de oxycorte de tubos	RB Elektron 650/1200	RB Elektron 950/1500	RB Elektron 950/2000	
		80-650 mm ~3"-~25 1/2"	200-950 mm ~7 1/2"-~37 1/2"	200-950 mm ~7 1/2"-~37 1/2"	
		650-1200 mm ~25 1/2"-~48"	950-1500 mm ~37 1/2"-~59"	950-2000 mm ~37 1/2"-~79"	
 $\beta + \beta' \text{ max. } \leq 120^\circ$		80-1200 mm ~3"-48"	200-1500 mm ~7 1/2"-~59"	200-2000 mm ~7 1/2"-~79"	
 Upm, rpm		0-4 min <sup>-1</sup>	0-2 min <sup>-1</sup>	0-0,75 min <sup>-1</sup>	
 v		0-1400 mm/min 0-~55"/min	0-1400 mm/min 0-~55"/min	0-1400 mm/min 0-~55"/min	
 Pt		20000 N	27500 N	27500 N	
 P1		20000 Nm	35000 Nm	35000 Nm	
 P2		6000 Nm	12000 Nm	20000 Nm	
 P3		25000 N bei 80-650 mm $\phi$ ~3"-~25 1/2"	50000 N bei 200-950 mm $\phi$ ~7 1/2"-~37 1/2"	50000 N	
		380 V, 50 Hz Drehstrom/three phase	380 V, 50 Hz Drehstrom/three phase	380 V, 50 Hz Drehstrom/three phase	
cteur		35 A	35 A	35 A	
nissible nissible		+5°C - +40°C	+5°C - +40°C	+5°C - +40°C	
		Acetylen-Sauerstoff/oxygen C <sub>2</sub> H <sub>2</sub> -O <sub>2</sub>	Acetylen-Sauerstoff/oxygen C <sub>2</sub> H <sub>2</sub> -O <sub>2</sub>	Acetylen-Sauerstoff/oxygen C <sub>2</sub> H <sub>2</sub> -O <sub>2</sub>	
			▲	▲	▲
			▲	▲	▲
			▲	▲	▲
			▲	▲	▲
			▲	▲	▲
asma		▲	▲	▲	
g on ht- inder.	Tolérances de coupe en fonction des différences du tube de la surface cylindrique circulaire.	Tolérancias de corte dependientes de la desviación del tubo de la forma de un cilindro circular y recto.			

# RAIL TYPE 20 KG S 20 / 20 KG S 20 RAIL

DEFINITION DU PROFIL CONFORME AUX SPÉCIFICATIONS TECHNIQUES DE LA NORME DIN 5901 / SECTION FROM DIN 5901 STANDARD

**HAUTEUR / HEIGHT :** 100 mm  
**PATIN / BASE :** 82 mm  
**BOUDIN / HEAD :** 44 mm

Spécifications techniques détaillées : voir page 10  
 Retained technical specifications, see page 10

## RAIL

Masse linéique théorique  
 Theoretical weight kg/m 19,8

Moment d'inertie Ix  
 Moment of inertia cm<sup>4</sup> 346

Module d'inertie Ix/v  
 Modulus of inertia cm<sup>3</sup> 66,8

Section  
 Section cm<sup>2</sup> 25,26

Résistance à la traction  
 Tensile strength N/mm<sup>2</sup> 540 à 680

Boulon d'éclisse  
 correspondant

TRCO HU 16 x 70

Suitable fishbolt

TRCO HU 16 x 70

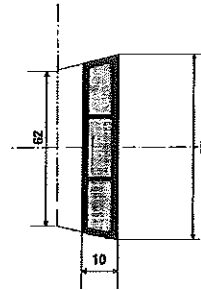
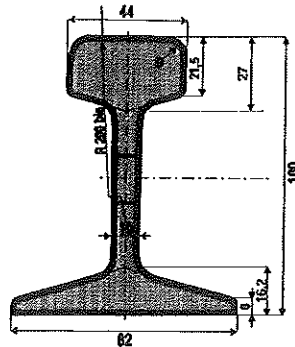

### DIAGRAMMES DE PERÇAGE / DIAGRAMS OF DRILLING

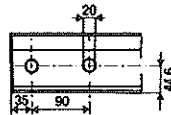

RAIL

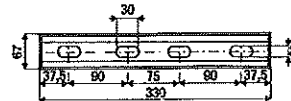

ECLISSE / FISHPLATE



# RAIL TYPE 26 KG / 26 KG RAIL

DEFINITION DU PROFIL CONFORME AUX SPÉCIFICATIONS TECHNIQUES DE LA NORME NF A 45-309 / SECTION FROM NF A 45-309 STANDARD

**HAUTEUR / HEIGHT :** 110 mm  
**PATIN / BASE :** 100 mm  
**BOUDIN / HEAD :** 50 mm

Spécifications techniques détaillées sur demande  
 Retained technical specifications on request

## RAIL

Masse linéique théorique  
 Theoretical weight kg/m 26,27

Moment d'inertie Ix  
 Moment of inertia cm<sup>4</sup> 551,4

Module d'inertie Ix/v  
 Modulus of inertia cm<sup>3</sup> 97,7

Section  
 Section cm<sup>2</sup> 33,46

Résistance à la traction  
 Tensile strength N/mm<sup>2</sup> 680 à 880

Boulon d'éclisse  
 correspondant

TRCO 20 x 90

Suitable fishbolt

TRCO 20 x 90

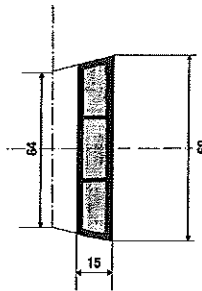
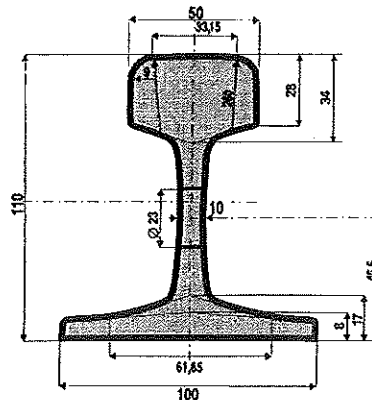

### DIAGRAMMES DE PERÇAGE / DIAGRAMS OF DRILLING



RAIL

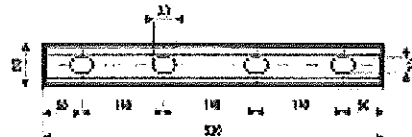

ECLISSE / FISHPLATE



**LE SPÉCIALISTE DU RAIL ET MANUTENTION SUR RAIL**

**RAIL AND ON-RAIL HANDLING SPECIALIST**

**SIEGE SOCIAL - REGISTERED OFFICE**  
 23, rue de la Boétie - 75008 PARIS - FRANCE  
 S.A. au capital de 400.000 € - Limited Company with a capital of 400.000 €  
 SIREN 702 033 077 - NAF 352Z

**SERVICES COMMERCIAUX - COMMERCIAL SERVICES**  
 24, rue du 8 Mai 1945 - 95340 PERSAN - FRANCE  
 Tél. : 01 39 37 45 45 - Fax : 01 39 37 45 44  
 www.patry.fr - e-mail : info@patry.fr